



**FAISALABAD INDUSTRIAL ESTATE DEVELOPMENT &
MANAGEMENT COMPANY**

Office of Chief Executive Officer, FIEDMC
1st Floor, FCCI Complex, East Canal Road Canal Road, Faisalabad
Tel: (041) 9230231-4 Fax: (041) 9230235

GALLOP TENDER NOTICE (RE-INVITATION)

1. FAISALABAD INDUSTRIAL ESTATE DEVELOPMENT & MANAGEMENT COMPANY, FAISALABAD, invites sealed tenders from fabricators/contractors for the following work:

S. Nr.	Name of Work
1.	Construction and Installation of Car Parking Shed at M-3 Industrial City, Near Sahianwala Interchange M-3 Motorway, Faisalabad.

2. Following may be the scope of Works with the tentative quantities:

Sr. No.	Particulars	Qty	Unit	Rate (Rs.)	Amount (Rs.)
1	Excavation in all soils as required including all equipment, labor etc. complete in all respect to the satisfaction of CRE/FIEDMC	83	CFT		
2	Compaction of the bed of the foundation including all equipment, labor etc. complete in all respect to the satisfaction of CRE/FIEDMC	30	SFT		
3	Placing of PCC 1:4:8 as per the drawings including cost of materials, transpiration, labor, equipment etc. complete in all respect to the satisfaction of CRE/FIEDMC	8	CFT		
4	Placing of PCC 1:2:4 as per the drawings including cost of materials, labor, transpiration, equipment etc. complete in all respect to the satisfaction of CRE/FIEDMC	75	CFT		
5	Providing/Fixing M.S Pipe 3" Square 14 gauge (red oxide applied) to be placed/fixed as per the drawings including cost of materials, transportation, labor, equipment, welding etc. compete in all respect to the satisfaction of CRE/FIEDMC	270	FT		

6	Providing/Fixing M.S Pipe 2" (+- 1/8") Square 16 gauge (red oxide applied) to be placed/fixe as per the drawings including cost of materials, transportation, labor, equipment, welding etc. compete in all respect to the satisfaction of CRE/FIEDMC	506	FT		
7	Providing/Fixing M.S Pipe 1" Square 16 gauge (red oxide applied) to be placed/fixe as per the drawings including cost of materials, transportation, labor, equipment, welding etc. compete in all respect to the satisfaction of CRE/FIEDMC	686	FT		
8	2 coats of best quality enamel paint to be applied on all the steel works including cost of materials, transportation, labor, equipment etc. compete in all respect to the satisfaction of CRE/FIEDMC	1	LS		
9	Providing and fixing 3ply fiber glass sheet best quality of approved color to be fixed as per the drawings complete in all respect to the satisfaction of CRE/FIEDMC. Including all fastenings, clamps etc.	1733	SFT		

CFT stands for Cubic Foot
SFT stands for Square Foot
FT stands for running Foot
LS stands for Lump Sum

3. Bidders may obtain further information from the Office of the Chief Executive Office, FIEDMC, 1st Floor, FCCI Complex, East Canal Road, Canal Park, Faisalabad.
4. All bids must be accompanied by a Bid Security in the amount of not less than **2% (TWO Percent) of Bid Amount** and must be delivered to Office of the Chief Executive Officer, FIEDMC, 1st Floor, FCCI Complex, East Canal Road, Canal Park, Faisalabad, at or before **1500** hours, on 23.04.2015. Bids will be opened at 1530 hours on the same day, in the presence of bidder's representatives who choose to attend at the same address.
5. The bidder shall submit his bid in a sealed envelope.
6. Any bid received by the Employer after the deadline for submission of bids will be returned unopened.

7. Any bid not accompanied by an acceptable Bid Security shall be rejected by the Employer as non-responsive.
8. FIEDMC may reject all or any bids subject to relevant provision of Punjab Procurement Rules 2014 (PPR-2014).
9. Bids/ tenders with any conditions shall be rejected.
10. Bids shall be valid for a period of 01 month
11. Bids shall be quoted in Pak Rupees and payment shall be in Pak. Rupees.
12. Time for Completion of Work shall be one month from the date of receipt of Letter of Acceptance, which shall be issued to lowest evaluated bidder after the evaluation of bids.
13. Bid Security furnished by the lowest evaluated bidder shall be treated as Performance Security and shall be returned after the issuance of Completion Certificate, which shall be issued within 07 days from the date of Taking Over of the Works. Bid Security of the unsuccessful bidders shall be returned after the evaluation of bids.
14. All Works shall be supervised by the Consultant, M/S Osmani & Company/FIEDMC.
15. Payment shall be made by the Employer as per the amounts certified by the Chief Resident Engineer, subsequent to the submission of bill by the Fabricator/Contractor. Payment shall be made within seven days of the receipt of bill from Chief Resident Engineer.
16. Site will be handed over to the Fabricator/Contractor at the issuance of Letter of Acceptance.
17. All Works shall be to the satisfaction of CRE/FIEDMC. PPRA-2014 shall apply; these are available at <http://ppra.punjab.gov.pk/downloads>
18. All steel works shall be coated with red oxide and two coats of best quality enamel paint as approved by CRE/FIEDMC
19. All the materials' specifications shall be to the satisfaction of CRE/FIEDMC and as approved.
20. Welding electrodes may be the locally manufactured electrodes subject to the approval of CRE/FIEDMC.
21. Fabrication, Welding, Installation, Completion shall be to the satisfaction of CRE/FIEDMC.
22. The Fabricator/Contractor shall be responsible for providing labor for each and every works regarding the completion of Works.
23. All costs are required to be included in the rates quoted by the bidder.
24. No escalation shall be admissible on any ground and the price(s) shall remain fixed.
25. The Fabricator/Contractor shall provide for all parts of the Works to be completed in every respect. Notwithstanding that any details, accessories, etc. required for the complete installation and satisfactory operation of the Works, are not specifically mentioned in the Specifications, BOQ, Drawings etc. such details shall be considered as

included in the Contract Price. In this regard, the bidders are required to visit the Site.

26. Taxes shall be deducted as per the law. This bidder shall furnish NTN Certificate with his bid.
27. All the Works shall be inspected by CRE/FIEDMC/Reps.
28. Place of Arbitration shall be Faisalabad
29. Payment may be made as follows; bidder will intimate with in his bid one of the following option for payment:

Option-1

- i. 75% Advance against Bank Guarantee/DD/PO (if not taken then at Completion of Works)
- ii. 10% upon Completion of Shed in every respect subject to the satisfaction of the Employer.
- iii. 15% Payment after one month of Completion of Shed subject to the satisfaction of the Employer

Option-2

- iv. 50% at the delivery at Site of materials i.e. MS pipes, fiber glass sheet, aggregate for concrete to be used in the Works, welding materials etc.
- v. 35% upon Completion of Shed in every respect subject to the satisfaction of the Employer.
- vi. 15% Payment after one month of Completion of Shed subject to the satisfaction of the Employer

30. BOQ and Drawings are attached and bidder to fill the BOQ and to sign all the documents including this invitation, drawings, BOQ etc.
31. Payments will be made for the quantities of executed works (quantities given in the BOQ may vary). Bidder to include all costs of the materials, transportation, labor, welding, scaffolding, taxes and any other cost required to complete the Works in all respects to the satisfaction of the CRE/FIEDMC. Payment shall be made as per the items mentioned in the BOQ and if any material required to complete the works is used by the Fabricator/Contractor then no separate payment for this shall be made; bidders has to include this effect in his bid/quotation.

Chief Executive Officer
Faisalabad Industrial Estate
Development & Management
Company

Drawings

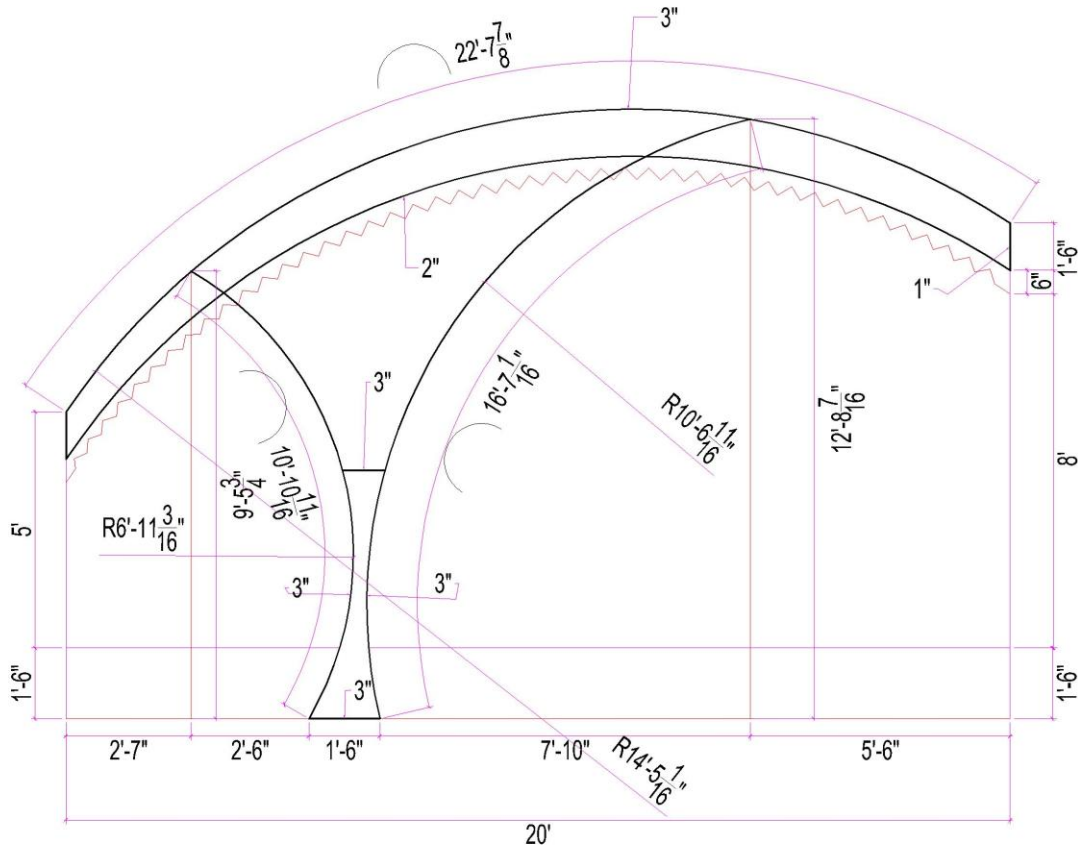

CAR PARKING PLAN

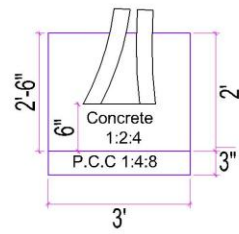
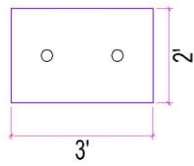

FOUNDATION PLAN

